

*FAMU-FSU College of Engineering*

*Design for Manufacturing: Spring 2016*

---

*Team #18*

*SAR Imager*

*Instructors: Dr. Nikhil Gupta and Dr. Chiang Shih*

*Sponsor: Michael Blue*

*Faculty Advisor: Dr. Dorr Campbell*

**NORTHROP GRUMMAN**

The logo for Northrop Grumman, featuring the company name in a bold, blue, sans-serif font. Below the text is a thick, blue, curved line that starts under the 'N' and sweeps upwards and to the right.

| <i>Members:</i>        | <i>ID:</i>    |
|------------------------|---------------|
| <i>Luke Baldwin</i>    | <i>lrb11e</i> |
| <i>Josh Dennis</i>     | <i>jad11d</i> |
| <i>Kaylen Nollie</i>   | <i>kn11e</i>  |
| <i>Desmond Pressey</i> | <i>drp14</i>  |

*Submitted:  
April 1, 2016*



# Table of Contents

|   |           |
|---|-----------|
| <b>Table of Figures.....</b>            | <b>3</b>  |
| <b>1. Introduction.....</b>             | <b>4</b>  |
| <b>2. Design for Manufacturing.....</b> | <b>5</b>  |
| 2.1 Structure Design.....               | 5         |
| 2.2 Horn Holder Design .....            | 6         |
| <b>3. Design for Reliability .....</b>  | <b>7</b>  |
| 3.1 1-Dimensional Model.....            | 7         |
| 3.2 3-Dimensional Model.....            | 8         |
| 3.3 Error and Convergence.....          | 11        |
| 3.4 Summary .....                       | 12        |
| <b>4. Design for Economics .....</b>    | <b>13</b> |
| <b>5. Conclusion .....</b>              | <b>14</b> |
| <b>References .....</b>                 | <b>15</b> |

## Table of Figures

|  |    |
|--|----|
| Figure 1: Structure Design .....                                     | 5  |
| Figure 2: Horn Holder Design Assembly .....                          | 6  |
| Figure 3: 1-Dimensional model stress .....                           | 7  |
| Figure 4: von Mises Stress for vertical bar .....                    | 8  |
| Figure 5: 3D FEM Analysis Loading.....                               | 9  |
| Figure 6: Stress values along vertical beam.....                     | 10 |
| Figure 7: FEM Analysis.....  | 10 |
| Figure 8: Comparison of values obtained from different methods ..... | 11 |
| Figure 9: Mechanical team cost breakdown .....                       | 13 |
| Figure 10: Comparison of competitive homeland security devices.....  | 13 |

# 1. Introduction

This report covers the basis of the design process. This includes the manufacturing and assembly, the reliability, and the economics of the design. The purpose of this design is to produce a working, reliable prototype using the synthetic aperture radar concept for homeland security.

## 2. Design for Manufacturing

### 2.1 Structure Design

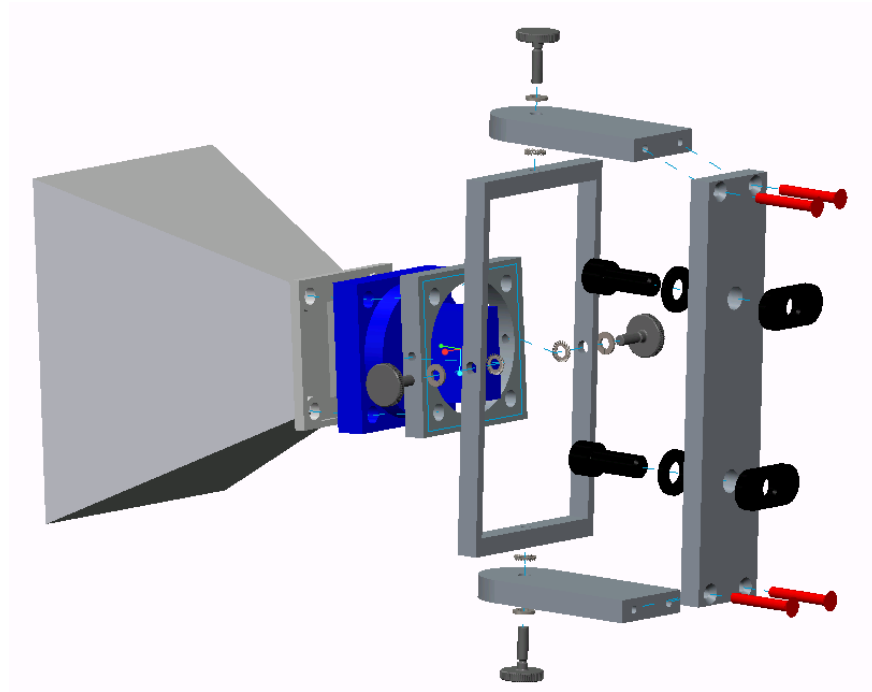
The design for manufacturing started with a very extensive 3D modeling process to allow the team to assemble the structure and horn holders with minimal issues. The team utilized multiple manufacturing processes and sources to accomplish our assembly. To begin, the team ordered all of the parts for the structure from an 80-20 aluminum supplier. The beams for the structure were pre-cut to fit the dimensions determined by our 3D model. The structure was built by first building the bottom frame without the caster wheels, then adding the middle brace, followed by the horizontal brace, support braces, and diagonal braces. The assembly of the structure only took approximately 5 hours, which was slightly shorter than anticipated. There are many components to the structural design. The reasoning for this is to provide our team with the maximum amount of flexibility and adjustability with the structure. Where a commercial product would most likely have less components, this design allows for the team to be able to make changes on the fly to complete our goal.



**Figure 1: Structure Design**

## 2.2 Horn Holder Design

As with the structure, the horn holder design was completed first using 3D modeling. The horn holder components were made out of .25 inch aluminum plates that were water jetted to the shapes indicated by the 3D model. The pieces were then tapped and threaded to fit the determined fasteners. The fastening process included thumb and flat-head screws as well as lock and star washers. The assembly process can be seen in the exploded view in Figure 2. The design for the horn holders was altered over time to include more components and fasteners. The reasoning for this was to allow for flexibility as well as save time in the machine shop. Instead of having parts welded together and risk misalignment, it was decided to add fasteners to the back to have control over the assembly time and alignment.



**Figure 2: Horn Holder Design Assembly**

## 3. Design for Reliability

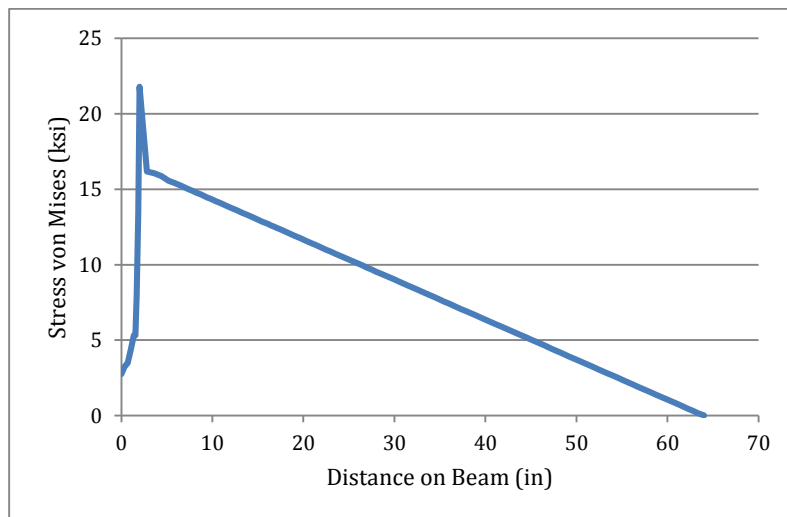
### 3.1 1-Dimensional Model

The primary concern is that the horizontal bar will deflect downwards, and that the top half of the vertical bar causes deflection due to its unsupported nature. The signal processing done to the received signal requires the structure to be very rigid, as any deflection of the structure would cause the received signal to be processed off of its true phase, causing significant error.

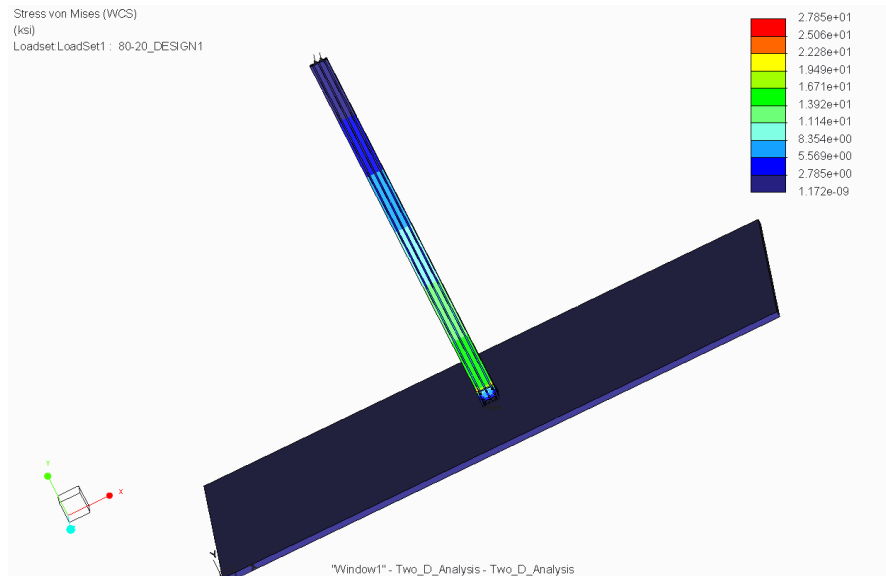
In order to produce some preliminary values for the analysis, the 3D model will be simplified to a 1D model. Since the longest unsupported span is on the top half of the structure, this will be analyzed. It will be represented as a cantilevered beam, analyzed using the Euler-Bernoulli beam theory. The transverse deflection of the beam is governed by the fourth-order differential equation:

$$\frac{d^2}{dx^2} \left( EI \frac{d^2 w}{dx^2} \right) + c_f w = q(x) \quad \text{for } 0 < x < L \quad (1)$$

At the very top of the beam, a 100 pound force will be applied on the top of the beam along the weak axis of the cross section.



**Figure 3: 1-Dimensional model stress**



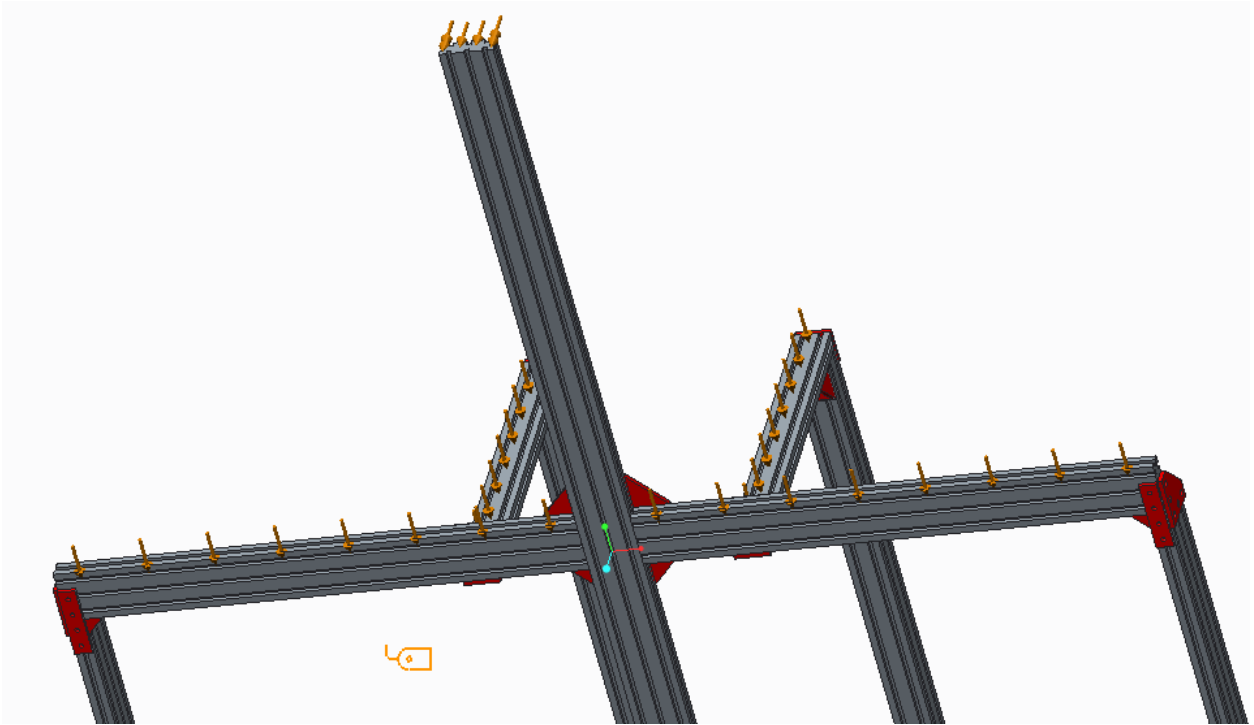
**Figure 4: von Mises Stress for vertical bar**

The area of primary interest is the bottom portion of the structure. Stress concentrations could develop in the bottom few inches because that is where it is physically clamped to the bottom surface. In the 0 to 5 inch range, there is a spike in the stress where the bracket attaches to the structure. The curve shown indicates that the mesh should be refined due to the drastic changes in slope. This region will receive further attention in subsequent analysis.

### 3.2 3-Dimensional Model

The full design will be testing using a 3D model. The forces applied will be the 100 pounds on the top vertical bar (same as 1D), as well as 100 pounds on each of the top of the rear supports going downwards, and 100 pounds in the downward direction on each of the horizontal arms that are in-plane with the radar array.

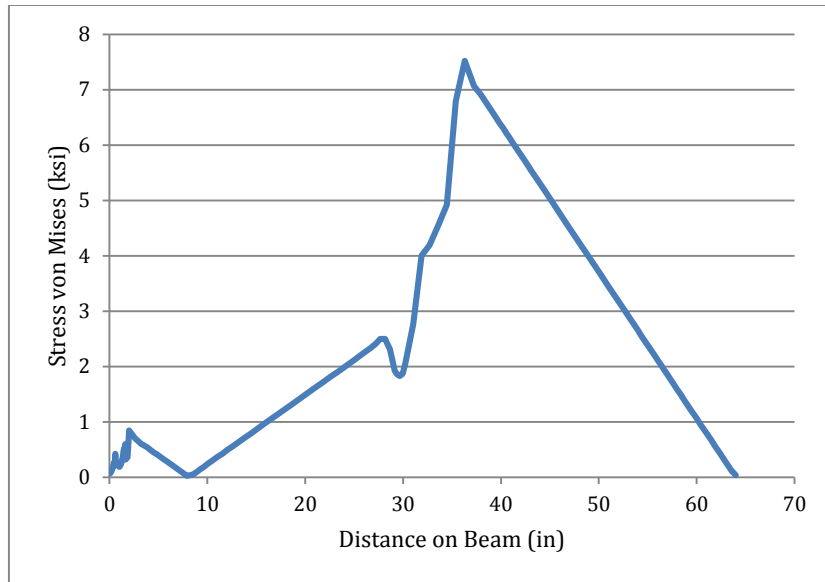




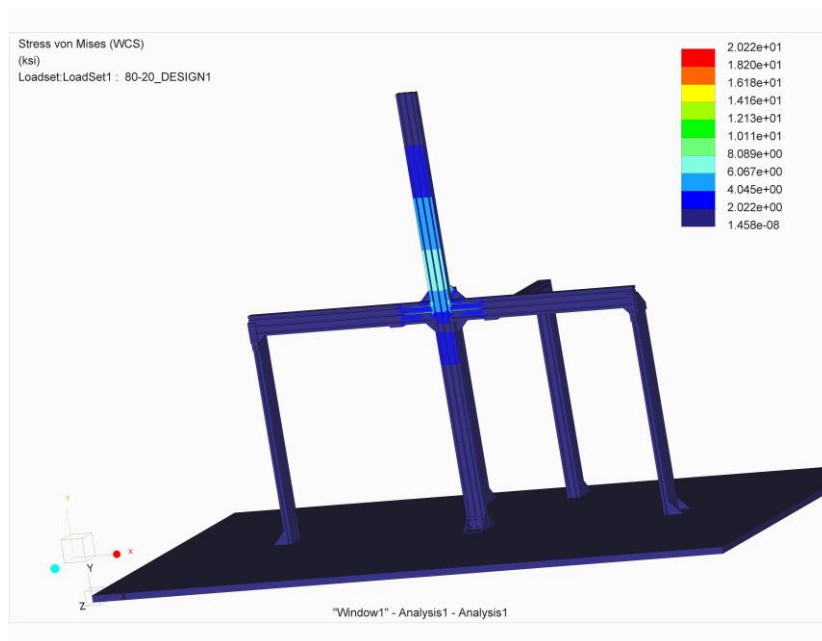
**Figure 5: 3D FEM Analysis Loading**

*The arrows along each surface indicates a 100 pound distributed load. A combined loading for 400 pounds in the vertical, and 100 pounds in the horizontal.*

The maximum stress obtained was 7.5 ksi. In regards to the design of the project, this was very optimal considering the maximum allowable stress of the material is 60 ksi. The stress values for the computer analysis is also shown on **Error! Reference source not found..**



**Figure 6: Stress values along vertical beam**

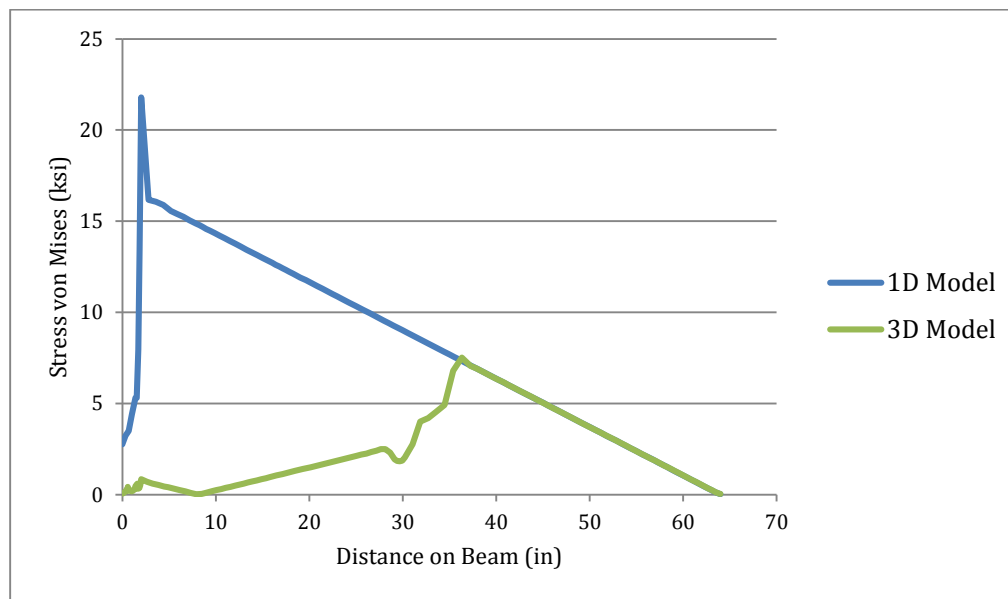


**Figure 7: FEM Analysis**

The important difference between the 1D and 3D analysis is that the maximum stress is significantly less (7.5 ksi instead of 21.8 ksi) because there were additional supports added to the model. Instead of the center vertical beam having to support all of the load, the other in-plane bars and rear support bars share the load. Another difference about the analysis shown in **Error!**

**Reference source not found.** is that the mesh was greatly refined. There are 146 data points along the line selected to be plotted in **Error! Reference source not found.**, and 110 in **Error! Reference source not found.**. Considering that this is examining a line within a 3 dimensional structure, the number of meshes increase exponentially.

The data obtained from the analysis was very predictable. The comparison between the computational model and the theoretical model revealed that the values for the computational model had higher stress. Ideally, the stress analysis would have relatively the same values for the maximum stress. The max von Mises stress is 21.8 ksi in 1D, and 7.5 ksi in 3D.



**Figure 8: Comparison of values obtained from different methods**

### 3.3 Error and Convergence

An understanding of finite element analysis must be applied to any results obtained from software. Although a computer is a useful tool, it does not have an inherent understanding of the concepts involved. Results must undergo a “sanity check.” Because all of the results shown in **Error! Reference source not found.** are very similar, it is unlikely that one method of analysis introduced an extraordinary amount of error. When the computational analysis was conducted, it was specified in the application that the convergence should reach within 3% at the final iterations. Additionally, the analysis was done using a 6 degree polynomial. Although a higher degree does

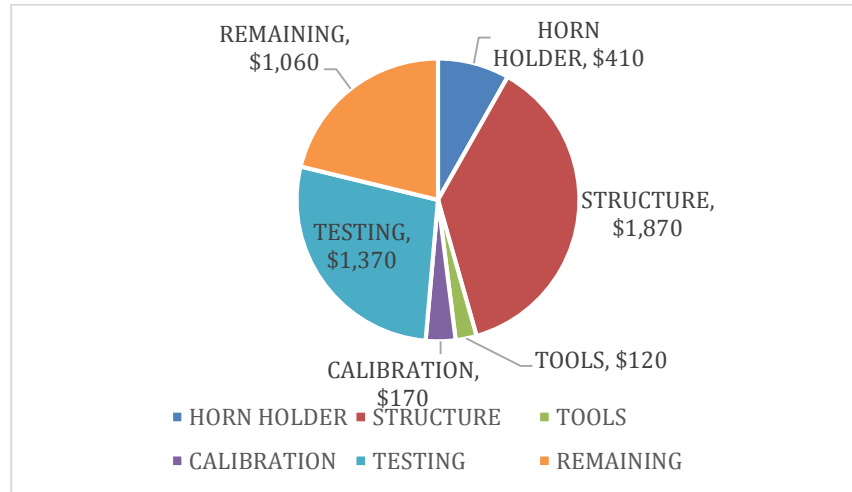
not always mean a better result, often it does – especially in complex geometries or loadings. Because the results were consistent, and the safety factor used was very high, any small errors are acceptable for this application.

### 3.4 Summary

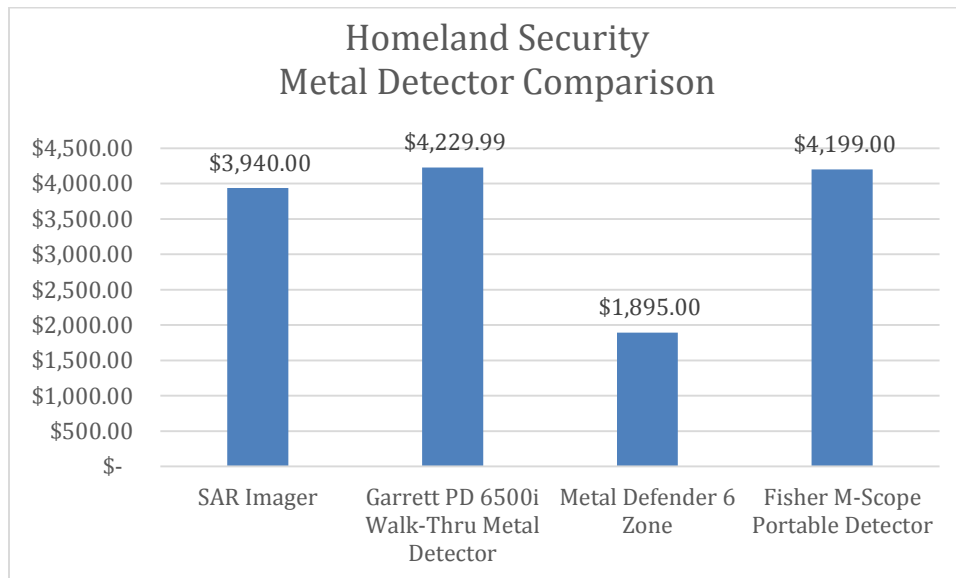
Because the motivation of this research was to offer insight into a creating a product for a senior design project, the success of the report is measured by whether it offers useful information. In all versions of the analysis, the stress on the structure is well within acceptable bounds. Not only is the calculated stress low, the forces applied to produce that stress were above anything the structure would normally experience. Also final structure has more support than the tested 3D model, thus there is not expected issues. The minimum design has been verified to be able to endure any stresses applied.

## 4. Design for Economics

The project was sponsored with \$5,000 dollars to complete the mechanical team’s objectives. Thus far we have been able to complete our designs using \$3,940. The breakdown of the costs is in Figure 9 below. Compared to other high end homeland security metal detectors, our design cost is very comparable. The graphic comparison is in Figure 10.



**Figure 9: Mechanical team cost breakdown**



**Figure 10: Comparison of competitive homeland security devices**

## 5. Conclusion

This second generation design process has refined what was accomplished last year by allowing for flexibility to achieve results. The structure is much more lightweight and the manufacturing process has been much more punctual. The design has also been analyzed using the 3D model stress tests and deemed to be reliable. The project will also be completed with excess money left over and at a cost that should produce a product that is competitive on the market. The next order of business is to assemble the electrical equipment and test the functionality.

## References

1. Northrop Grumman. *WikiMedia*. [Online]  
[https://upload.wikimedia.org/wikipedia/commons/4/47/B-2\\_Spirit\\_original.jpg](https://upload.wikimedia.org/wikipedia/commons/4/47/B-2_Spirit_original.jpg)icles, Ph.D. dissertation, Florida State University, Tallahassee, FL, June 2014..
2. Radar Tutorial. [Online]  
[http://www.radartutorial.eu/20.airborne/pic/sar\\_principle.print.png](http://www.radartutorial.eu/20.airborne/pic/sar_principle.print.png).
3. Cammuse, Matthew. Final Presentation. *SAR Imager Home*. [Online]  
[http://eng.fsu.edu/me/senior\\_design/2015/team27/Webpage/presentations/Team%20E%2311\\_Milestone%20%237%20Presentation\\_%20Final%20Report.pptx](http://eng.fsu.edu/me/senior_design/2015/team27/Webpage/presentations/Team%20E%2311_Milestone%20%237%20Presentation_%20Final%20Report.pptx).
4. Final Report. *SAR Imager Home*. [Online]  
[http://eng.fsu.edu/me/senior\\_design/2015/team27/](http://eng.fsu.edu/me/senior_design/2015/team27/).
5. Platform Trucks. *McMaster-Carr*. [Online] <http://www.mcmaster.com/#carts/=zgsvoa>.
6. Business Sectors. *Northrop Grumman*. [Online]  
<http://www.northropgrumman.com/AboutUs/BusinessSectors/Pages/default.aspx>.
7. Cooper, Helene. Northrop Grumman Wins \$21.4 Billion Pentagon Contract. *The New York Times*. 2015.
8. Kremer, Kem. James Webb Space Telescope's Giant Sunshield Test Unit Unfurled First Time. *Universe Today*. 2014.
9. Synthetic Aperture Radar. *Radar Basics*. [Online]  
<http://www.radartutorial.eu/20.airborne/ab07.en.html>.
10. Synthetic Aperture Radar. *Lockheed Martin*. [Online]  
<http://www.lockheedmartin.com/us/products/sar.html>.